

Van Seat

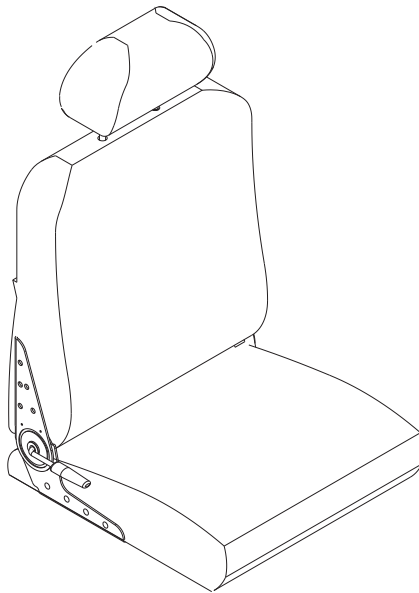

DEALER: This manual **MUST** be given to the user of the product.

USER: **BEFORE** using this product, read this manual and save for future reference.

For more information regarding
Invacare products, parts, and services,
please visit www.invacare.com



Yes, you can.

⚠ WARNING

A qualified technician MUST perform the initial set up of this wheelchair. Also, a qualified technician MUST perform all procedures in the service manual.

DO NOT use this product or any available optional equipment without first completely reading and understanding these instructions and any additional instructional material such as owner’s manuals, service manuals or instruction sheets supplied with this product or optional equipment. If you are unable to understand the warnings, cautions or instructions, contact a healthcare professional, dealer or technical personnel before attempting to use this equipment - otherwise, injury or damage may occur.

⚠ ACCESSORIES WARNING

Invacare products are specifically designed and manufactured for use in conjunction with Invacare accessories. Accessories designed by other manufacturers have not been tested by Invacare and are not recommended for use with Invacare products.

REFERENCE DOCUMENTS

Refer to the table below for part numbers of additional documents which are referenced in this manual.

MANUAL	PART NUMBER
MK6i™ Electronics Field Reference Guide	1141471
MK6i Electronics Service Manual	1143203

⚠ WARNING

Refer to wheelchair base owner’s manual for additional safety and operation information.

NOTE: Updated versions of this manual are available on www.invacare.com.

TABLE OF CONTENTS

REFERENCE DOCUMENTS	2
REGISTER YOUR PRODUCT	4
SPECIAL NOTES	5
LABEL LOCATIONS	6
TYPICAL PRODUCT PARAMETERS	7
SECTION 1—GENERAL GUIDELINES	8
Controller Settings/Repair or Service	8
Operation Information.....	8
A Note About Drive Lock-Out.....	10
Accessories	11
Rain Test.....	11
Weight Training.....	11
Weight Limitation.....	11
SECTION 2—SAFETY/HANDLING OF WHEELCHAIRS	12
Pinch Points.....	12
SECTION 3—SAFETY INSPECTION/TROUBLESHOOTING	13
Safety Inspection Checklists.....	13
Inspect/Adjust Initially	13
Inspect/Adjust Weekly.....	13
Inspect/Adjust Monthly.....	14
Inspect/Adjust Periodically.....	14
Troubleshooting.....	14
SECTION 4—ARMS	15
Adjusting Armrests	15
Angle	15
Height	15
SECTION 5—SEAT	16
Adjusting the Headrest	16
Adjusting the Back Angle.....	16
SECTION 6—FRONT RIGGINGS	17
Installing/Removing Front Riggings	17
Installing.....	17
Removing	18
Adjusting Footrest Height	18
Model PHWH93	18
Model PH904A and PHAL4A.....	18

TABLE OF CONTENTS

Replacing Heel Loops	19
Raising/Lowering Elevating Front Riggings	19
Adjusting/Replacing Telescoping Front Rigging Supports	20
Removing/Installing the Center Mount Footrest	22
Removing	22
Installing.....	22
Adjusting the Height of the Center Mount Footrest.....	23
Adjusting the Angle of the Manual Center Mount Footrest	24
Adjusting the Footplate Angle	24
After 2/14/07	24
Before 2/15/07	25
Adjusting the Tension of the Flip Up Footplate	25
LIMITED WARRANTY	28

REGISTER YOUR PRODUCT

The benefits of registering include:

1. Safeguarding your investment.
2. Ensuring long-term maintenance and servicing of your product.
3. Receiving updates with product information, maintenance tips and industry news.

Register ONLINE at warranty.invacare.com

Please have your model number and purchase date available to complete your registration.

Any registration information you submit will only be used by Invacare Corporation and protected as required by applicable laws and regulations.

SPECIAL NOTES

Signal words are used in this manual and apply to hazards or unsafe practices which could result in personal injury or property damage. Refer to the table below for definitions of the signal words.

SIGNAL WORD	MEANING
DANGER	Danger indicates an imminently hazardous situation which, if not avoided, will result in death or serious injury.
WARNING	Warning indicates a potentially hazardous situation which, if not avoided, could result in death or serious injury.
CAUTION	Caution indicates a potentially hazardous situation which, if not avoided, may result in property damage or minor injury or both.

NOTICE

THE INFORMATION CONTAINED IN THIS DOCUMENT IS SUBJECT TO CHANGE WITHOUT NOTICE.

WHEELCHAIR USER

As a manufacturer of wheelchairs, Invacare endeavors to supply a wide variety of wheelchairs to meet many needs of the end user. However, final selection of the type of wheelchair to be used by an individual rests solely with the user and his/her healthcare professional capable of making such a selection. Invacare highly recommends working with a certified rehab technology supplier and/or a member of NRRTS or RESNA.

WHEELCHAIR TIE-DOWN RESTRAINTS AND SEAT RESTRAINTS

As of this date, the Department of Transportation has not approved any tie-down systems for transportation of a user while in a wheelchair, in a moving vehicle of any type. It is Invacare's position that users of wheelchairs should be transferred into appropriate seating in vehicles for transportation and use be made of the restraints made available by the auto industry. Invacare cannot and does not recommend any wheelchair transportation systems.

WARNING

Invacare products are specifically designed and manufactured for use in conjunction with Invacare accessories. Accessories designed by other manufacturers have not been tested by Invacare and are not recommended for use with Invacare products.

The seat positioning strap is a positioning belt only. It is not designed for use as a safety device withstanding high stress loads such as auto or aircraft safety belts. If signs of wear appear, belt must be replaced immediately.

Wheelchairs should be examined during maintenance for signs of corrosion (water exposure, incontinence, etc.). Electrical components damaged by corrosion should be replaced **IMMEDIATELY**.

Wheelchairs that are used by incontinent users and/or are frequently exposed to water may require replacement of electrical components more frequently.

LABEL LOCATIONS

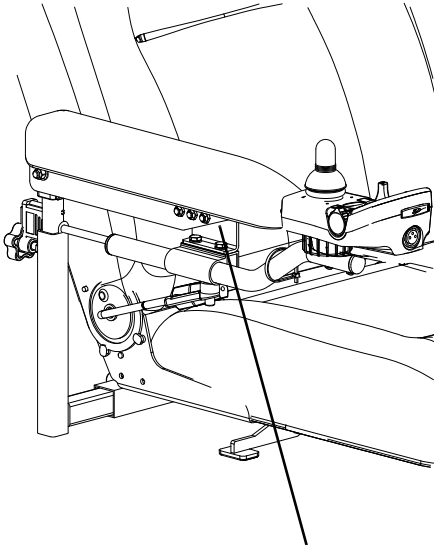

Weight Capacity Label
located here

TYPICAL PRODUCT PARAMETERS

	18-INCH VAN SEAT	20-INCH VAN SEAT	22-INCH VAN SEAT
SEAT WIDTH RANGE:	18 inches	20 inches	22 inches
SEAT DEPTH:	16 -18 inches	18-20 inches	20-22 inches
BACK HEIGHT W/O HEADREST:	18 inches	18 inches	18 inches
BACK ANGLE RANGE			
SEMI-RECLINE:	35° to 115°	35° to 115°	35° to 115°
FULL RECLINE:	35° to 170°	35° to 170°	35° to 170°
UPHOLSTERY:	Grey Vinyl, Grey Cloth, Tan Vinyl		
SEAT-TO-FLOOR:	22½ to 23½ inches (Cushion Not Compressed)		
OVERALL WIDTH (NO JOYSTICK):	25-7/8 inches		
OVERALL HEIGHT:	36-49¼ inches		
OVERALL LENGTH:	39 inches (With Footboard Folded)		
FOOTRESTS/LEGRESTS:	Flip Up, Depth and Height Adjustable, Footboard, Swingaway Front Rigging, Elevating Legrest		
ARMRESTS:	Adjustable Angle, Depth and Width		
INCLINE CAPABILITY:	9°		

NOTE: Based on 18-inch deep Van seat.

SECTION I—GENERAL GUIDELINES

⚠ WARNING

SECTION I - GENERAL GUIDELINES contains important information for the safe operation and use of this product.

Controller Settings/Repair or Service

DO NOT service or adjust your wheelchair while occupied, unless otherwise noted.

Wheelchairs should be examined during maintenance for signs of corrosion (water exposure, incontinence, etc.). Electrical components damaged by corrosion should be replaced immediately.

Wheelchairs that are used by incontinent users and/or are frequently exposed to water may require replacement of electrical components more frequently.

Operation Information

Performance adjustments should only be made by professionals of the healthcare field or persons fully conversant with this process and the driver's capabilities. Incorrect settings could cause injury to the driver, bystanders, damage to the wheelchair and to surrounding property.

After the wheelchair has been set-up, check to make sure that the wheelchair performs to the specifications entered during the set-up procedure. If the wheelchair does NOT perform to specifications, turn the wheelchair Off immediately and reenter set-up specifications. Repeat this procedure until the wheelchair performs to specifications.

ALWAYS shift your weight in the direction you are turning. DO NOT shift your weight in the opposite direction of the turn. Shifting your weight in the opposite direction of the turn may cause the inside drive wheel to lose traction and the wheelchair to tip over.

DO NOT make sharp turns in the forward or reverse direction at excessive speed. Failure to observe this warning can cause the wheelchair to tip over and may result in injury to users, bystanders and/or damage to product.

DO NOT shift your weight or sitting position toward the direction you are reaching as the wheelchair may tip over.

DO determine and establish your particular safety limits by practicing bending, reaching and transferring activities in the presence of a qualified healthcare professional before attempting active use of the wheelchair.

DO NOT attempt to reach objects if you have to move forward in the seat.

DO NOT attempt to reach objects if you have to pick them up from the floor by reaching down between your knees.

DO NOT lean over the top of the back upholstery to reach objects behind you, as this may cause the wheelchair to tip over.

ALWAYS keep hands and fingers clear of moving parts to avoid injury.

DO NOT store items under seat - interference with seat latch may result.

DO NOT use an escalator to move a wheelchair between floors. Serious bodily injury may occur.

DO NOT engage or disengage the motor release levers until the power is in the Off position.

DO NOT attempt to stop a moving wheelchair with wheel locks. Wheel locks are not brakes.

DO NOT operate on roads, streets or highways.

DO NOT climb, go up or down ramps or traverse slopes greater than 9°.

NEVER leave an unoccupied wheelchair on an incline.

Invacare strongly recommends proceeding down ramps or slopes at half speed or slower and to avoid hard braking or sudden stops.

DO NOT leave elevating legrests in the fully extended position when proceeding down ramps or slopes.

DO NOT attempt to move up or down an incline with a water, ice or oil film.

DO NOT attempt to drive over curbs or obstacles. Doing so may cause your wheelchair to turn over and cause bodily harm or damage to the wheelchair.

DO NOT leave the power button in the On position when entering or exiting your wheelchair.

DO NOT attempt to lift the wheelchair by any removable (detachable) parts. Lifting by means of any removable (detachable) parts of the wheelchair may result in injury to the user or damage to the wheelchair.

DO NOT stand on the frame of the wheelchair.

DO NOT stand on the footplates/footboard. When getting in or out of the wheelchair, make sure that the footboard or footplates are in the upward position or swing the footrests towards the outside of the wheelchair.

Before attempting to transfer in or out of the wheelchair, every precaution should be taken to reduce the gap distance. Turn both casters parallel to the object you are transferring onto. Also be certain the power is Off and wheel locks are engaged to prevent the wheels from moving.

When determining the depth of the telescoping front frame tubes, make sure the rear of the footrests do not interfere with the movement of the front casters. Otherwise damage to the wheelchair may result or may impede proper operation.

Before performing any maintenance, adjustment or service verify that On/Off switch on the joystick is in the Off position.

ALWAYS wear your seat positioning strap. The seat positioning strap is a positioning belt only. It is not designed for use as a safety device withstanding high stress loads such as auto or aircraft safety belts. If signs of wear appear, belt must be replaced immediately.

With regards to seat/chest positioning straps - it is the obligation of the DME dealer, therapists and other healthcare professionals to determine if a seat/chest positioning strap is required to ensure the safe operation of this equipment by the user. Serious injury can occur in the event of a fall from a wheelchair.



Avoid storing or using the wheelchair near open flame or combustible products. Serious injury or damage to property may result.

A Note About Drive Lock-Out

NEVER operate the wheelchair while the back is in any reclined/back angle position over 20° relative to the vertical position. If the drive lock-out does not stop the wheelchair from operating in a recline/back angle position over 20° relative to the vertical position, DO NOT operate the wheelchair. DO NOT attempt to adjust the drive lock-out. Have the wheelchair serviced by a qualified technician.

The wheelchair user MUST have a clear line of sight to drive safely. On initial chair delivery and after adjusting the back angle or drive lock-out switch, recline the seat back to the farthest driving position immediately before drive lock-out engages and ensure there is a clear line of sight present in which to drive the wheelchair. If a clear line of sight is not present, have the back angle repositioned or readjust the lockout angle such that safe driving with a clear line of sight is achieved. Otherwise injury or damage may occur.

One of the following will occur when the drive lock-out feature has been activated:

-  TILT WARNING displays on the joystick or display unit.
-  SPM Inhibited displays on the joystick or display unit.
- SPJ+ joysticks Only - Left to right chase alternating with a steady display.

Drive lock-out is a feature designed to prevent the wheelchair from being driven after the seating system has been reclined beyond 20°* relative to the vertical position. The back can be positioned at a 10° relative offset to the seat base, thereby resulting in a back angle potential of 30° before which the drive lock-out is activated. This may affect the wheelchair user's line of sight while driving. Make sure the wheelchair user can see properly to ensure safe driving.

**NOTE: 20° back angle can be any combination of recline, back angle and/or surface angle.*

NOTE: Refer to Typical Product Parameters on page 7 for recline angle ranges.

Accessories

EXTREME care should be exercised when using oxygen in close proximity to electric circuits and other combustible materials. Contact your oxygen supplier for instruction in the use of oxygen.

Rain Test

Invacare has tested its power wheelchairs in accordance with ISO 7176 “Rain Test.” This provides the end user or his/her assistant sufficient time to remove his/her power wheelchair from a rain storm and retain wheelchair operation.

DO NOT leave power wheelchair in a rain storm of any kind.

DO NOT use power wheelchair in a shower.

DO NOT store power wheelchair in a damp area for an extended period of time.

Direct exposure to excessive rain or dampness may cause the wheelchair to malfunction electrically and mechanically, may cause the wheelchair to prematurely rust or may damage the upholstery.

Weight Training

Invacare DOES NOT recommend the use of its wheelchairs as a weight training apparatus. Invacare wheelchairs have NOT been designed or tested as a seat for any kind of weight training. If occupant uses said wheelchair as a weight training apparatus, Invacare shall NOT be liable for bodily injury and the warranty is void.

Weight Limitation

Weight limitation varies depending on wheelchair base. The weight limitation of the wheelchair can be found on the weight limitation label. Refer to [Label Locations](#) on page 6.

SECTION 2—SAFETY/HANDLING OF WHEELCHAIRS

Refer to wheelchair base owner's manual for complete safety/handling information.

Pinch Points

⚠ WARNING

DO NOT store or place items under the seat.

Pinch point may occur when adjusting the arm angle position.

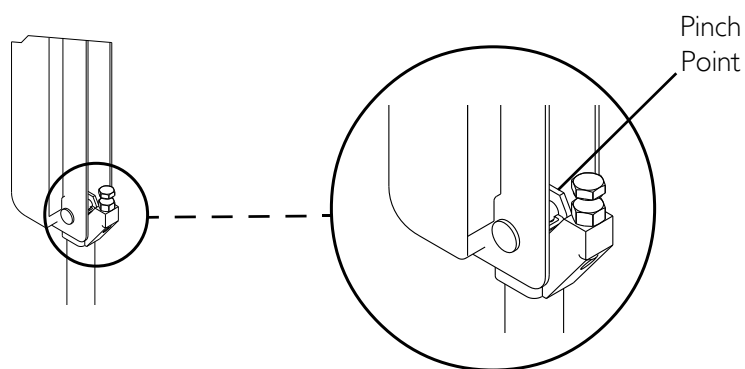

FIGURE 2.1 Pinch Points

SECTION 3—SAFETY INSPECTION/ TROUBLESHOOTING

NOTE: Every six months or as necessary take your wheelchair to a qualified dealer for a thorough inspection and servicing. Regular cleaning will reveal loose or worn parts and enhance the smooth operation of your wheelchair. To operate properly and safely, your wheelchair must be cared for just like any other vehicle. Routine maintenance will extend the life and efficiency of your wheelchair.

NOTE: Refer to wheelchair base owner's manual for additional safety inspection and troubleshooting information.

Safety Inspection Checklists

CAUTION

As with any vehicle, wheels and tires should be checked periodically for cracks and wear and should be replaced as necessary.

Initial adjustments should be made to suit your personal body structure needs and preference. Thereafter follow these maintenance procedures:

Inspect/Adjust Initially

- Ensure adjustable height arms operate and lock securely.
- Ensure armrest pads sit flush against arm tubes.
- Ensure seat is secured to wheelchair frame.
- Ensure seat release latch is functional. Replace if necessary.
- Ensure all fasteners are secure.
- Clean upholstery and armrests.
- Check that all labels are present and legible. Replace if necessary.

Inspect/Adjust Weekly

- Ensure seat is secured to wheelchair frame.
- Ensure seat and/or back upholstery have no rips and do not sag. Replace if necessary.
- Ensure seat release latch is not worn and is functional. Replace if necessary.
- Ensure arm pivot points are not worn and/or loose. Replace if necessary.

Inspect/Adjust Monthly

- Ensure all fasteners are secure.
- Inspect for any loose hardware on the wheelchair.
- Inspect the seat positioning strap for signs of wear. Replace if worn or damaged.
- Ensure that the buckle on the seat positioning strap latches. Replace if necessary.
- Verify that the hardware that attaches the seat positioning strap to the seat frame is secure and undamaged. Replace if necessary.

Inspect/Adjust Periodically

- Ensure adjustable height arms operate and lock securely.
- Ensure arm pivot points are not worn and/or loose. Replace if necessary.
- Ensure armrest pads sit flush against arm tubes.
- Ensure seat and/or back upholstery have no rips and do not sag. Replace if necessary.
- Ensure seat release latch is not worn. Replace if necessary.
- Clean upholstery and armrests.
- Check that wiring is routed and secured properly to ensure that wiring does NOT become entangled and damaged.
- Inspect electrical components for signs of corrosion. Replace if corroded or damaged.
- Check that all labels are present and legible. Replace if necessary.

Troubleshooting

NOTE: For troubleshooting information and explanation of error codes, refer to the wheelchair base owner's manual and the individual Electronics Manual supplied with each wheelchair.

SECTION 4—ARMS

⚠ WARNING

After ANY adjustments, repair or service and before use, make sure that all attaching hardware is tightened securely - otherwise injury or damage may result.

Before performing any maintenance, adjustment or service verify that On/Off switch on the joystick is in the Off position.

Adjusting Armrests

⚠ WARNING

Pinch point may occur when adjusting the arm angle position (Detail “A”).

Angle

NOTE: For this procedure, refer to Detail “A” of FIGURE 4.1.

1. Lift up the armrest.
2. Loosen the jam nut.
3. Adjust the socket screw up or down to the desired arm angle position.
4. Tighten the jam nut.
5. To determine the same angle for the opposite armrest, count the exposed threads after the jam nut has been tightened.
6. Repeat STEPS 1-4 for opposite armrest, if necessary.

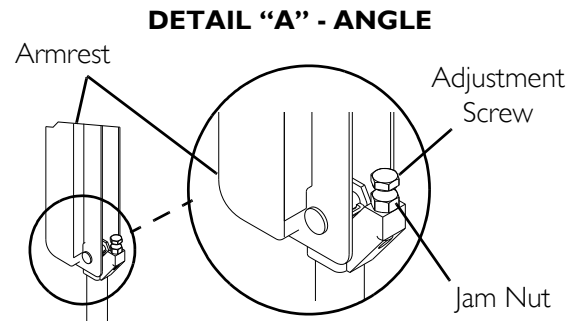

Height

NOTE: For this procedure, refer to Detail “B” of FIGURE 4.1.

1. Remove the socket screw that secures the armrest to the seat frame assembly.
2. Adjust the armrest to one of four positions.
3. Reinstall the socket screw that secures the armrest to the seat frame assembly and tighten securely.

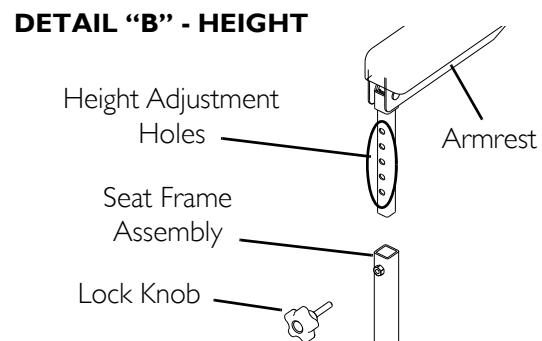

FIGURE 4.1 Adjusting Armrests

SECTION 5—SEAT

⚠ WARNING

After **ANY** adjustments, repair or service and before use, make sure that all attaching hardware is tightened securely - otherwise injury or damage may result.

Before performing any maintenance, adjustment or service verify that **On/Off** switch on the joystick is in the **Off** position.

Adjusting the Headrest

NOTE: For this procedure, refer to FIGURE 5.1.

1. To raise headrest, lift headrest Up to desired position.

NOTE: Headrest is locked in position when an audible “click” is heard.

2. To lower headrest, push release tab towards the inside of the wheelchair. Lower headrest to desired position.

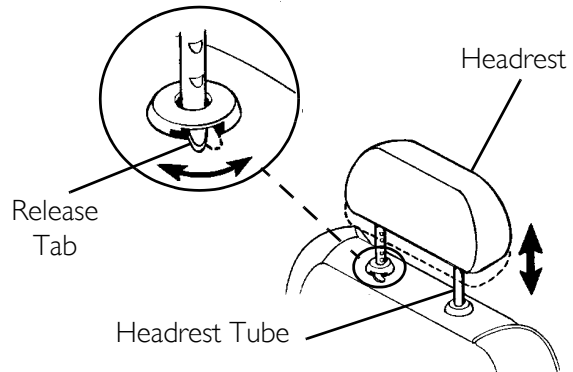

FIGURE 5.1 Adjusting the Headrest

Adjusting the Back Angle

NOTE: For this procedure, refer to FIGURE 5.2.

1. Lift up on the release handle and adjust seat to desired angle.
2. Let go of the release handle to lock the back in position.

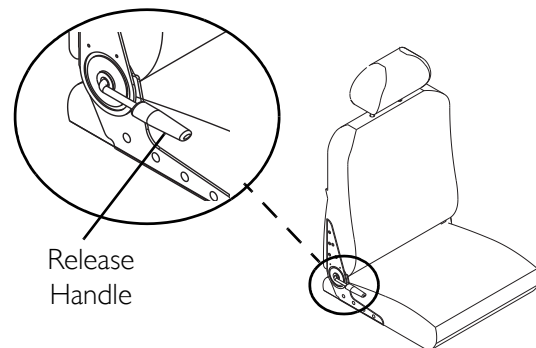

FIGURE 5.2 Adjusting the Back Angle

SECTION 6—FRONT RIGGINGS

⚠ WARNING

After **ANY** adjustments, repair or service and before use, make sure that all attaching hardware is tightened securely - otherwise injury or damage may result.

DO NOT stand on the front riggings, otherwise damage may occur. When getting in or out of the wheelchair, make sure that the footplates on the front riggings are in the upward position or moved out of the way.

Before performing any maintenance, adjustment or service verify that **On/Off** switch on the joystick is in the **Off** position.

While the wheelchair is moving, minimum ground clearance for the front rigging is three inches. If the wheelchair is not moving, the front rigging **MUST** maintain a minimum of one inch ground clearance - otherwise personal injury and damage may result.

Installing/Removing Front Riggings

CAUTION

If front riggings are used, then the seat **MUST** be adjusted to the highest mounting position - otherwise damage may occur.

NOTE: For this procedure, refer to FIGURE 6.1.

Installing

1. If necessary, remove the footboard.
Refer to owner's manual shipped with the wheelchair.
2. Turn front rigging to the side (open footplate is perpendicular to wheelchair) and position mounting holes in the front rigging hinge plates with hinge pins on the wheelchair frame.
3. Install the front rigging hinge plates onto the hinge pins on the wheelchair frame.
4. Push the front rigging towards the inside of the wheelchair until it locks into place.
NOTE: The footplate will be on the inside of the wheelchair when locked in place.
5. Repeat STEPS 1-4 for opposite side of wheelchair.

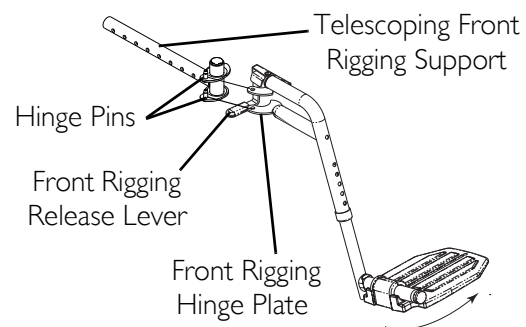

FIGURE 6.1 Installing/Removing Front Riggings

Removing

1. Push the front rigging release lever inward and rotate the footrest out.
2. Lift up on front rigging and remove from the wheelchair.
3. Repeat STEPS 1-2 for opposite side of wheelchair.

Adjusting Footrest Height

Model PHWH93

NOTE: For this procedure, refer to FIGURE 6.2.

1. Remove any accessories from the footrest(s).
2. Remove the footrest from the wheelchair. Refer to [Installing/Removing Front Riggings](#) on page 17.

NOTE: Lay footrest on a flat surface to simplify section.

3. Remove the hex bolt, coved washers and locknut that secure the lower footrest to the footrest support.
4. Reposition the lower footrest to the desired height.
5. Reinstall hex bolt, coved washers and locknut that secure lower footrest to footrest support. Tighten securely.
6. Repeat STEPS 1-5 for the opposite side of the wheelchair footrest, if necessary.
7. Reinstall the footrest(s) onto the wheelchair. Refer to [Installing/Removing Front Riggings](#) on page 17.
8. Reinstall any accessories onto the footrest(s).

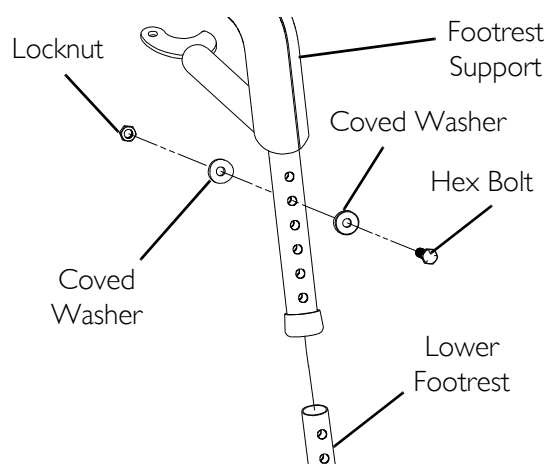

FIGURE 6.2 Adjusting Footrest Height - Model PHWH93

Model PH904A and PHAL4A

NOTE: For this procedure, refer to FIGURE 6.3.

NOTE: PH904A style front rigging shown. PHAL4A front rigging adjust the same way.

1. Loosen, but do not remove the lug bolt and locknut that secure the lower footrest to the footrest support.
2. Reposition the lower footrest to the desired height.

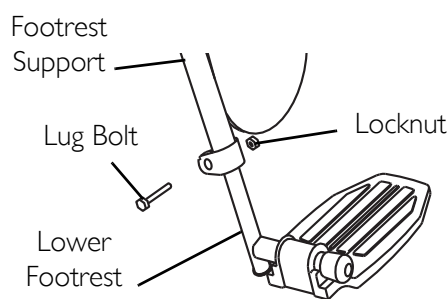

FIGURE 6.3 Adjusting Footrest Height - Model PH904A and PHAL4A

3. Securely tighten the lug bolt and locknut that secure the lower footrest to the footrest support.
4. Repeat STEPS 1-3 for the opposite side of the wheelchair footrest, if necessary.

Replacing Heel Loops

NOTE: For this procedure, refer to FIGURE 6.4.

1. Note the position of hex bolt, coved washers and locknut for reinstallation.
2. Remove the hex bolt, coved washers and locknut that secure the lower footrest to the footrest support.
3. Remove the lower footrest.
4. Remove the phillips bolt, spacer and locknut that secure the existing heel loop to the lower footrest.
5. Slide the existing heel loop off the lower footrest.
6. Replace heel loop.
7. Reverse STEPS 1-6 to reassemble.

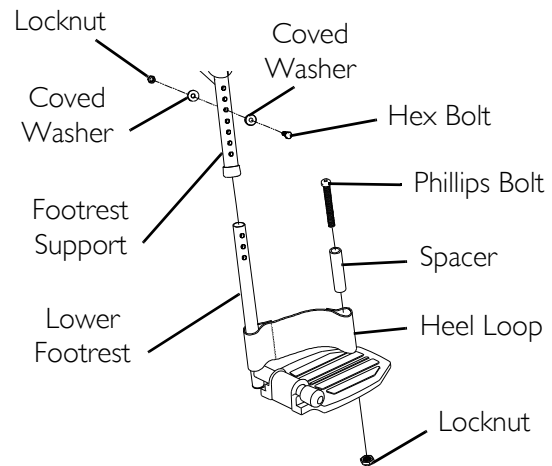

FIGURE 6.4 Replacing Heel Loops

NOTE: When securing heel loop to lower footrest, tighten the phillips screw and locknut until the spacer is secure.

Raising/Lowering Elevating Front Riggings

NOTE: For this procedure, refer to FIGURE 6.5.

1. Perform one of the following:
 - Raising - Pull back on the release lever and raise front rigging to the desired height.
 - Lowering - Support front rigging with one hand away from the release lever. Push release lever downward with other hand.

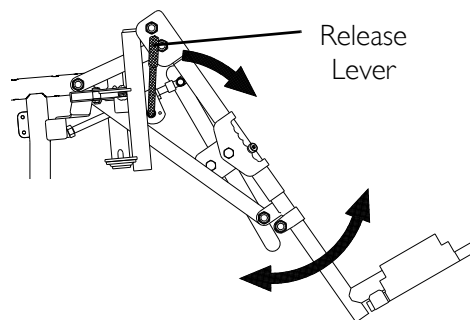

FIGURE 6.5 Raising/Lowering Elevating Front Riggings

Adjusting/Replacing Telescoping Front Rigging Supports

NOTE: For this procedure, refer to FIGURE 6.6 on page 21.

NOTE: When adjusting the telescoping front rigging support depth, ensure the footplate does not interfere with the caster wheel rotation.

NOTE: Telescoping front rigging supports may be extended up to 2-inches from the wheelchair frame in 1-inch increments. This adjustment does not affect seat depth.

NOTE: When installing the front riggings support tubes, ensure that the hinge pins are on the outside of the wheelchair facing away from the seat frame.

1. Remove the two socket bolts and locknuts that secure telescoping front rigging support to the seat frame.
2. Perform one of the following:
 - Adjusting - Align the appropriate mounting hole of the telescoping front rigging support with the front mounting hole in the seat frame tubes to achieve the desired depth as shown in FIGURE 6.6.
 - Replacing - Perform the following steps:
 - i. Remove the existing telescoping front rigging support from the wheelchair frame.
 - ii. Insert the new telescoping front rigging support into the seat frame.
 - iii. Align the appropriate mounting hole of the telescoping front rigging support with the front mounting hole in the seat frame tubes to achieve the desired depth as shown in FIGURE 6.6.

NOTE: The footplate will be on the inside of the wheelchair when locked in place.

3. Using the two socket bolts and locknuts, secure the telescoping front rigging support to the seat frame as shown in FIGURE 6.6.
4. If necessary, repeat STEPS 1-3 on remaining telescoping front rigging support.

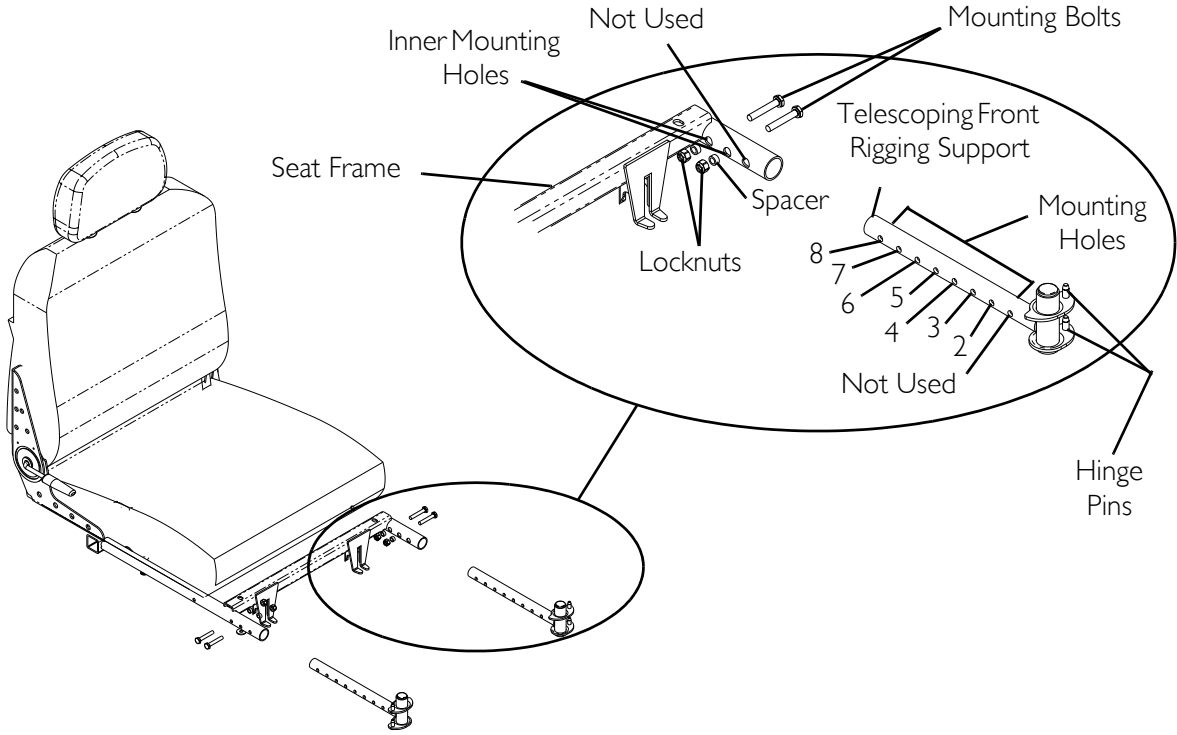

STANDARD POSITION			1 INCH OUT			2 INCHES OUT		
18 inches wide	20 inches wide	22 inches wide	18 inches wide	20 inches wide	22 inches wide	18 inches wide	20 inches wide	22 inches wide
Holes 2 and 3	Holes 2 and 3	Holes 3 and 4	Holes 3 and 4	Holes 3 and 4	Holes 5 and 6	Holes 4 and 5	Holes 4 and 5	Holes 6 and 7

FIGURE 6.6 Adjusting/Replacing Telescoping Front Rigging Supports

Removing/Installing the Center Mount Footrest

NOTE: For this procedure, refer to FIGURE 6.7.

Removing

1. Remove the rigging pivot pin that secures the footrest to the mounting bracket of the seat frame.
2. Hold the footrest with one hand and engage the release lever with the other while simultaneously pulling the center mount footrest out of the mounting bracket of the seat frame.

Installing

1. Engage the release lever with one hand, hold the center mount footrest with the other, and insert the center mount footrest into the mounting bracket of the seat frame.
2. Reinstall the rigging pivot pin to secure the center mount footrest to the mounting bracket of the seat frame.

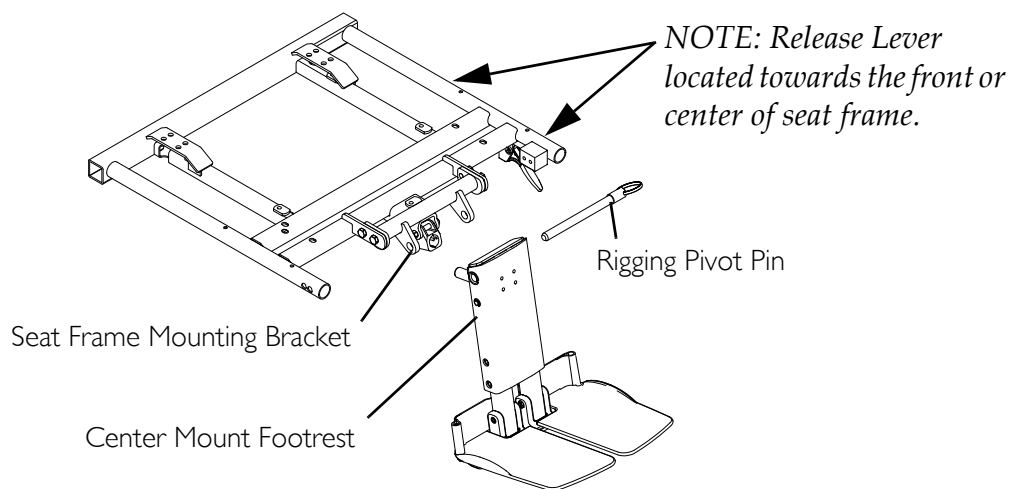

FIGURE 6.7 Removing/Installing the Center Mount Footrest

Adjusting the Height of the Center Mount Footrest

⚠ WARNING

While the wheelchair is moving, minimum ground clearance for the front rigging is three inches. If the wheelchair is not moving, the front rigging **MUST maintain a minimum of one inch ground clearance - otherwise personal injury and damage may result.**

NOTE: For this procedure, refer to FIGURE 6.8.

1. Remove the two mounting screws that secure the footrest extension tube to the extension tube housing.
2. Adjust the footrest extension tube to the desired height and align the corresponding holes to the mounting holes on the extension tube housing.
3. Reinstall the two mounting screws to secure the footrest extension tube to the extension tube housing. Securely tighten.
4. Repeat STEPS 1-3 for the other extension tube.

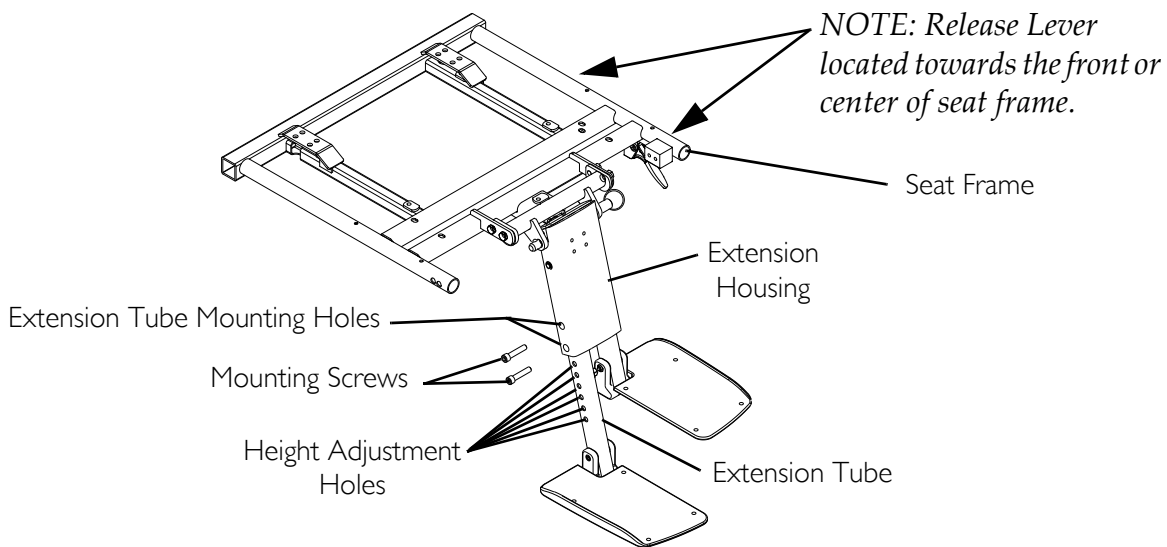

FIGURE 6.8 Adjusting the Height of the Center Mount Footrest

Adjusting the Angle of the Manual Center Mount Footrest

⚠ WARNING

While the wheelchair is moving, minimum ground clearance for the front rigging is three inches. If the wheelchair is not moving, the front rigging **MUST** maintain a minimum of one inch ground clearance - otherwise personal injury and damage may result.

NOTE: For this procedure, refer to FIGURE 6.8 on page 23 and FIGURE 6.9.

1. Engage the release lever with one hand (not shown) and move the center mount footrest to the desired angle with the other hand.

NOTE: Refer to FIGURE 6.8 on page 23 for the location of the release lever.

2. Disengage the release lever (not shown) to lock the center mount footrest in the new position.

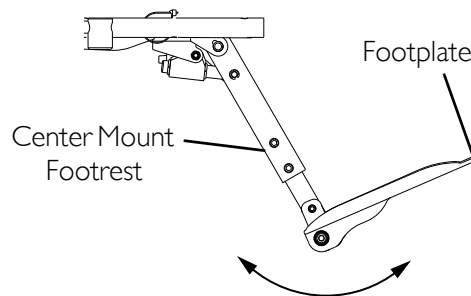

FIGURE 6.9 Adjusting the Angle of the Manual Center Mount Footrest

Adjusting the Footplate Angle

After 2/14/07

NOTE: For this procedure, refer to FIGURE 6.10.

1. Loosen, but **DO NOT** remove, the two rear mounting screws and side mounting screw.
2. Move the footplate to the desired angle.
3. Tighten the two rear mounting screws and side mounting screw to secure the footplate in the desired position.
4. Repeat STEPS 1 and 2 for the other footplate.

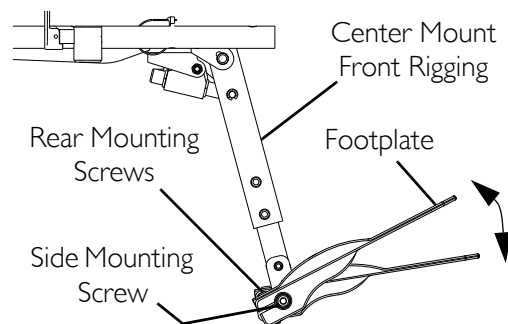

FIGURE 6.10 Adjusting the Footplate Angle - After 2/14/07

Before 2/15/07

NOTE: For this procedure, refer to FIGURE 6.11.

1. Loosen the footplate mounting screw and move the footplate to the desired angle.

NOTE: DO NOT remove the footplate mounting screw.

2. Tighten the footplate mounting screw to secure the footplate in the desired position.
3. Repeat STEPS 1 and 2 for the other footplate.

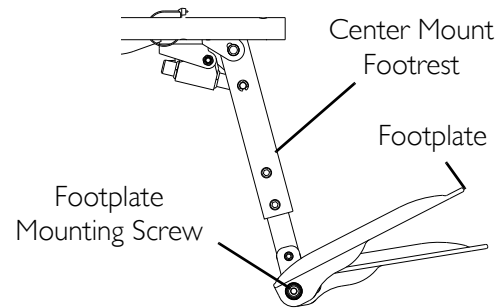

FIGURE 6.11 Adjusting the Footplate Angle - Before 2/15/07

Adjusting the Tension of the Flip Up Footplate

NOTE: For this procedure, refer to FIGURE 6.12.

NOTE: The tension can be adjusted to increase or decrease the rotation effort of the flip up footplates.

1. Loosen the mounting screw on the footrest angle hinge to decrease the rotation effort.

NOTE: DO NOT remove the footplate mounting screw.

2. Tighten the footrest angle hinge mounting screw to increase the rotation effort.
3. Repeat STEPS 1 and 2 for the other footplate.

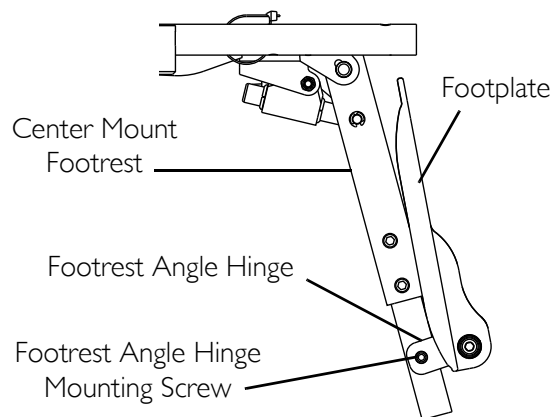

FIGURE 6.12 Adjusting the Tension of the Flip Up Footplate

NOTES

NOTES

LIMITED WARRANTY

PLEASE NOTE: THE WARRANTY BELOW HAS BEEN DRAFTED TO COMPLY WITH FEDERAL LAW APPLICABLE TO PRODUCTS MANUFACTURED AFTER JULY 4, 1975.

This warranty is extended only to the original purchaser who purchases this product when new and unused from Invacare or a dealer. This warranty is not extended to any other person or entity and is not transferable or assignable to any subsequent purchaser or owner. Coverage under this warranty will end upon any such subsequent sale or other transfer of title to any other person.

This warranty gives you specific legal rights and you may also have other legal rights which vary from state to state.

Invacare warrants the seat frame to be free from defects in materials and workmanship for a period of three (3) years from the date of purchase from Invacare or a dealer, with a copy of the seller's invoice required for coverage under this warranty. Invacare warrants all remaining components (excluding all upholstered materials and padded materials) for a period of one (1) year from the date of purchase from Invacare or a dealer, with a copy of the seller's invoice required for coverage under this warranty. If within such warranty periods any such product component shall be proven to be defective, the product component shall be repaired or replaced, at Invacare's option. This warranty does not include any labor or shipping charges incurred in replacement part installation or repair of any such product. Invacare's sole obligation and your exclusive remedy under this warranty shall be limited to such repair and/or replacement.

For warranty service, please contact the dealer from whom you purchased your Invacare product. In the event you do not receive satisfactory warranty service, please write directly to Invacare at the address on the bottom of the back cover. Provide dealer's name address, date of purchase, indicate nature of the defect and, if the product is serialized, indicate the serial number. Do not return products to our factory without our prior consent.

LIMITATIONS AND EXCLUSIONS: THE FOREGOING WARRANTY SHALL NOT APPLY TO SERIAL NUMBERED PRODUCTS IF THE SERIAL NUMBER HAS BEEN REMOVED OR DEFACED, PRODUCTS SUBJECT TO NEGLIGENCE, ACCIDENT, IMPROPER OPERATION, MAINTENANCE OR STORAGE, COMMERCIAL OR INSTITUTIONAL USE, PRODUCTS MODIFIED WITHOUT INVACARE'S EXPRESS WRITTEN CONSENT (INCLUDING, BUT NOT LIMITED TO, MODIFICATION THROUGH THE USE OF UNAUTHORIZED PARTS OR ATTACHMENTS); PRODUCTS DAMAGED BY REASON OF REPAIRS MADE TO ANY COMPONENT WITHOUT THE SPECIFIC CONSENT OF INVACARE, OR TO A PRODUCT DAMAGED BY CIRCUMSTANCES BEYOND INVACARE'S CONTROL, AND SUCH EVALUATION WILL BE SOLELY DETERMINED BY INVACARE. THE WARRANTY SHALL NOT APPLY TO PROBLEMS ARISING FROM NORMAL WEAR AND TEAR OR FAILURE TO ADHERE TO THE PRODUCT INSTRUCTIONS. A CHANGE IN OPERATING NOISE, PARTICULARLY RELATIVE TO MOTORS AND GEARBOXES DOES NOT CONSTITUTE A FAILURE OR DEFECT AND WILL NOT BE REPAIRED; ALL DEVICES WILL EXHIBIT CHANGES IN OPERATING NOISE DUE TO AGING. THE FOREGOING EXPRESS WARRANTY IS EXCLUSIVE AND IN LIEU OF ANY OTHER WARRANTIES WHATSOEVER, WHETHER EXPRESS OR IMPLIED, INCLUDING THE IMPLIED WARRANTIES OF MERCHANTABILITY AND FITNESS FOR A PARTICULAR PURPOSE, AND THE SOLE REMEDY FOR VIOLATIONS OF ANY WARRANTY WHATSOEVER, SHALL BE LIMITED TO REPAIR OR REPLACEMENT OF THE DEFECTIVE PRODUCT PURSUANT TO THE TERMS CONTAINED HEREIN. THE APPLICATION OF ANY IMPLIED WARRANTY WHATSOEVER SHALL NOT EXTEND BEYOND THE DURATION OF THE EXPRESS WARRANTY PROVIDED HEREIN AND INVACARE SHALL NOT BE LIABLE FOR ANY CONSEQUENTIAL OR INCIDENTAL DAMAGES WHATSOEVER; SOME STATES DO NOT ALLOW THE EXCLUSION OR LIMITATION OF INCIDENTAL OR CONSEQUENTIAL DAMAGE, OR LIMITATION OF HOW LONG AN IMPLIED WARRANTY LASTS, SO THE ABOVE EXCLUSION AND LIMITATION MAY NOT BE APPLICABLE.

THIS WARRANTY SHALL BE EXTENDED TO COMPLY WITH STATE/PROVINCIAL LAWS AND REQUIREMENTS.

Invacare Corporation www.invacare.com



Yes, you can.®

USA
One Invacare Way
Elyria, Ohio USA
44036-2125
800-333-6900

Canada
570 Matheson Blvd E Unit 8
Mississauga Ontario
L4Z 4G4 Canada
800-668-5324

All rights reserved. Trademarks are identified by the symbols ™ and ®. All trademarks are owned by or licensed to Invacare Corporation unless otherwise noted.

© 2008 Invacare Corporation

Part No 1143195

Rev D - 10/08

